

This Page Is Inserted by IFW Operations
and is not a part of the Official Record

BEST AVAILABLE IMAGES

Defective images within this document are accurate representations of the original documents submitted by the applicant.

Defects in the images may include (but are not limited to):

- BLACK BORDERS
- TEXT CUT OFF AT TOP, BOTTOM OR SIDES
- FADED TEXT
- ILLEGIBLE TEXT
- SKEWED/SLANTED IMAGES
- COLORED PHOTOS
- BLACK OR VERY BLACK AND WHITE DARK PHOTOS
- GRAY SCALE DOCUMENTS

IMAGES ARE BEST AVAILABLE COPY.

**As rescanning documents *will not* correct images,
please do not report the images to the
Image Problem Mailbox.**



INTERNATIONAL APPLICATION PUBLISHED UNDER THE PATENT COOPERATION TREATY (PCT)

<p>(51) International Patent Classification ⁶ : A46B 11/00</p>	<p>A1</p>	<p>(11) International Publication Number: WO 97/13428 (43) International Publication Date: 17 April 1997 (17.04.97)</p>
<p>(21) International Application Number: PCT/GB96/02509 (22) International Filing Date: 14 October 1996 (14.10.96) (30) Priority Data: 9521026.6 13 October 1995 (13.10.95) GB (71)(72) Applicant and Inventor: ROBINSON, Terence, Sidney [GB/GB]; A1 Systems, 48 Fore Street, Saltash, Cornwall PL12 6JL (GB). (74) Agent: HARRISON, Ivor, Stanley; Withers & Rogers, 4 Dyer's Buildings, Holborn, London EC1N 2JT (GB).</p>	<p>(81) Designated States: AL, AM, AT, AU, AZ, BA, BB, BG, BR, BY, CA, CH, CN, CU, CZ, DE, DK, EE, ES, FI, GB, GE, HU, IL, IS, JP, KE, KG, KP, KR, KZ, LC, LK, LR, LS, LT, LU, LV, MD, MG, MK, MN, MW, MX, NO, NZ, PL, PT, RO, RU, SD, SE, SG, SI, SK, TJ, TM, TR, TT, UA, UG, US, UZ, VN, ARIPO patent (KE, LS, MW, SD, SZ, UG), Eurasian patent (AM, AZ, BY, KG, KZ, MD, RU, TJ, TM), European patent (AT, BE, CH, DE, DK, ES, FI, FR, GB, GR, IE, IT, LU, MC, NL, PT, SE), OAPI patent (BF, BJ, CF, CG, CI, CM, GA, GN, ML, MR, NE, SN, TD, TG).</p> <p>Published <i>With international search report. Before the expiration of the time limits for amending the claims and to be republished in the event of the receipt of amendments.</i></p>	

(54) Title: APPLICATOR BRUSH

(57) Abstract

An applicator brush, especially a toothbrush, comprises a bristle-supporting head portion and a handle portion comprising a reservoir containing a working liquid composition, predetermined doses of the working liquid composition being delivered to the head portion in use. The working composition may be a dentifrice composition dispensed as a foam.

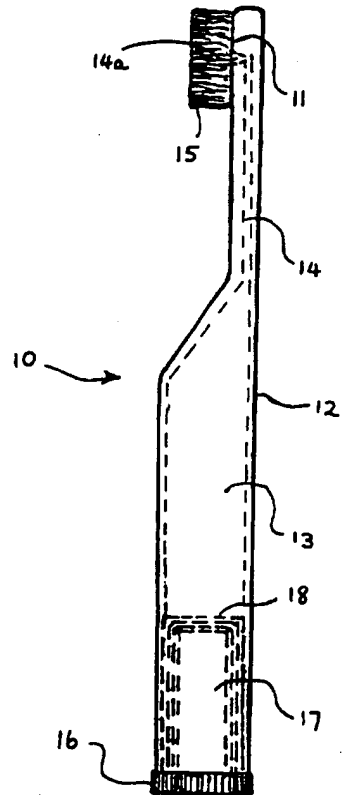

FOR THE PURPOSES OF INFORMATION ONLY

Codes used to identify States party to the PCT on the front pages of pamphlets publishing international applications under the PCT.

AM	Armenia	GB	United Kingdom	MW	Malawi
AT	Austria	GE	Georgia	MX	Mexico
AU	Australia	GN	Guinea	NE	Niger
BB	Barbados	GR	Greece	NL	Netherlands
BE	Belgium	HU	Hungary	NO	Norway
BF	Burkina Faso	IE	Ireland	NZ	New Zealand
BG	Bulgaria	IT	Italy	PL	Poland
BJ	Benin	JP	Japan	PT	Portugal
BR	Brazil	KE	Kenya	RO	Romania
BY	Belarus	KG	Kyrgystan	RU	Russian Federation
CA	Canada	KP	Democratic People's Republic of Korea	SD	Sudan
CF	Central African Republic	KR	Republic of Korea	SE	Sweden
CG	Congo	KZ	Kazakhstan	SG	Singapore
CH	Switzerland	LJ	Liechtenstein	SI	Slovenia
CI	Côte d'Ivoire	LK	Sri Lanka	SK	Slovakia
CM	Cameroon	LR	Liberia	SN	Senegal
CN	China	LT	Lithuania	SZ	Swaziland
CS	Czechoslovakia	LU	Luxembourg	TD	Chad
CZ	Czech Republic	LV	Larvia	TG	Togo
DE	Germany	MC	Monaco	TJ	Tajikistan
DK	Denmark	MD	Republic of Moldova	TT	Trinidad and Tobago
EE	Estonia	MG	Madagascar	UA	Ukraine
ES	Spain	ML	Mali	UG	Uganda
FI	Finland	MN	Mongolia	US	United States of America
FR	France	MR	Mauritania	UZ	Uzbekistan
GA	Gabon			VN	Viet Nam

APPLICATOR BRUSH

This invention relates to brushes which in use are intended to apply a liquid or semi-liquid medium to a substrate. Examples of such brushes include toothbrushes for application of a dentifrice, hairbrushes for application of a hair styling medium, or brushes for application of a cleaning solvent.

In the field of oral hygiene, the dental profession generally recommend that toothbrushes should be replaced after approximately 3-4 months use. However, it is recognised that toothbrushes nevertheless tend to be used beyond this time, when the bristles have become worn or distorted and their effectiveness impaired. Attempts have previously been made to make the user aware that the toothbrush needs replacing, for example by producing toothbrushes with coloured bristles, the colour fading through use such that, at the end of the useful life of the brush, the bristles have lost or changed their colour. However, there is still no particular incentive to compel the user to replace the brush at this stage.

Thus, it is one object of the invention to provide a brush, especially a toothbrush, which the user is more compellingly encouraged to replace once the brush has outlived its usefulness.

Additionally, when using a hair styling medium with a brush, an excess of medium may be applied to the hair before the brush is applied to the hair. The application of such an excess is wasteful and may adversely affect styling of the hair. Thus, it is a further object of the present invention to provide a brush for hairstyling in which the styling medium is delivered to the point of application.

The present invention provides a brush comprising a head portion with bristles extending therefrom, in which the brush includes a reservoir for containing a working liquid composition, the reservoir being in communication with one or more exit ducts in the head portion of the brush and the brush further including propellant means for the working composition and metering means operatively connected with the propellant means to dispense predetermined metered doses of the composition through the exit ducts.

By "working liquid composition" is meant a liquid-containing composition including one or more active ingredients, the composition being rendered flowable under pressure but being essentially form-stable in the absence of external influences. Such compositions include pastes, gels, foams and mousses.

Preferably, the brush is a toothbrush including a handle portion, the reservoir is contained in or constitutes the handle portion and the working composition comprises a dentifrice, and for convenience in the remainder of this specification, unless indicated otherwise, the invention will be described with reference to toothbrushes. For the avoidance of doubt, the term "dentifrice" is to be taken as including foams and gels as well as the more traditional pastes.

The propellant means may be mechanical such as a simple screw-threaded plunger, or one or more pistons acting as a jack. Alternatively, a propellant gas may be used.

Preferably, the dentifrice in the reservoir is under pressure, the pressure being applied by mechanical means,

for example by the use of telescopic tubes or biasing means such as a spring acting on a plunger within the reservoir, or by means of gas pressure using a gaseous propellant. The gas may be supplied from a source, for example a gas cylinder, within the handle portion or by the mixing together of chemicals, held within the brush, to generate gas *in situ*.

The metered dispensing is preferably effected by using means to restrict the movement of the propellant means, for example by using a pawl and ratchet arrangement such that movement along one notch of the ratchet wheel gives rise to delivery of the metered dose. When a gas propellant is used, a push-button may be provided which operates a valve to permit the passage of a predetermined amount of propellant gas such that a single press on the push-button gives rise to the delivery of a single metered dose. A push-button operated valve may also be used where the dentifrice is under pressure applied by biasing means, for example a spring. The user is preferably given an indication, for example an audible indication such as a clicking noise, that the complete dose has been dispensed.

Preferably the head portion of the brush and the handle portion are integral or at least are non-releasably attached together. In this manner, once the reservoir is empty, the brush is thrown away. Advantageously, the reservoir contains a 3-4 month supply of dentifrice. Thus, the brush is replaced according to the time scale recommended by the dental profession. However, the brush may be provided with a replaceable handle portion, optionally with locating means between the head and handle portions which limit the number of times that a replaceable handle portion can be attached.

Preferably, the exit ducts in the head portion are provided in the bristle-supporting base portion thereof. The dentifrice may be delivered through a single, preferably central, duct provided between the bristles, or through ducts within or among the individual tufts of bristles or even through ducts within individual bristles.

Preferably, the or each exit duct includes means to prevent access of air to the dentifrice contained in the reservoir and in any conduit between the reservoir and the duct, to prevent the dentifrice from drying and clogging the duct when the brush is left unused for long periods of time, whereby dentifrice in the exit duct will not impede the delivery of the next metered dose. This may be effected by means of a self-cleaning nozzle or by the use of a non-return valve.

Where a propellant gas is used to dispense the dentifrice, the reservoir may be connected to the exit duct by an elongate hollow element or lance-like hollow tube which is slidable in a blind-ended conduit within the head of the brush between respective positions in which the exit duct is sealed and in which it is open to allow dentifrice to be dispensed; the lance preferably is urged forwards by pressure, for example from a spring, to seal against the blind end of the conduit and may be retracted by the user to allow the metered dose of material to be expelled through the duct. The blind end of the conduit may be formed with a valve or sealing face which may be flat but which is preferably conical, to provide a more effective seal, and which may be formed from a resilient material such as butyl rubber. The open end of the lance may be slightly flared to clean the inner surface of the conduit in the region of the exit

duct and to prevent dentifrice from entering the conduit between the lance and conduit and upstream of the exit duct. The exit duct is preferably outwardly tapered or frusto-conical, to enable dentifrice remaining therein after use either to be readily washed out or removed as a plug before the next use.

Preferably, the brush is shaped such that it is a free-standing unit. Where a handle portion is provided, the base portion of the handle may be shaped to form a foot. The brush is preferably easily held, in use, and may be textured or ergonomically shaped, particularly on the surfaces to be gripped in use and may be decorated to render the brush attractive to the user.

Preferably, the brush has a close fitting cap to protect the bristles of the brush. Optionally, any activating push-button is also covered by a cap to prevent accidental activation of the push-button particularly when the brush is carried in luggage. Thus, the brush would not require any secondary packaging at the point of sale.

The brush is preferably manufactured from a plastics material, or from mixtures of plastics or aluminium or other metal or alloy. For example, the body of the brush may be formed from aluminium while the bristles may be formed of a plastics material. The brush may be made from biodegradable or recyclable materials. Where the brush is a toothbrush for applying a dentifrice, the brush is preferably disposable. However, where the brush is for example a hairbrush for applying a hair styling medium, the brush may be refillable; for example, a new reservoir of hair styling medium may be fitted to the brush.

Embodiments of the invention will now be described by way of example with reference to the accompanying drawings of which:

Figure 1 shows in side elevation a toothbrush according to the invention with a rotary-action dispenser;

Figure 2 shows a fragmentary detail of the dispenser in the toothbrush of Figure 1;

Figure 3 shows in side elevation a toothbrush according to the invention with gas propellant means; and

Figure 4 shows in longitudinal section the head portion of another toothbrush embodiment.

With reference first of all to Figure 1, a toothbrush 10 comprises a head 11 and a body 12 defining a reservoir 13 of dentifrice therein. The reservoir 13 communicates with the head 11 by means of a conduit 14 which opens among the bases of the bristles 15 in a frusto-conical nozzle 14a. A flexible diaphragm (not shown) is provided across the upper or narrow end of the nozzle and is provided with a cross-cut to form sector-like flaps. At the base of the body 12 is a knob 16 which, when turned, causes telescopic tubes 17 to extend, thus imparting pressure on the dentifrice via plunger 18 in sealing contact with the inner wall of the reservoir 13. Referring to Figure 2, the knob 16 includes a ratchet wheel 19 and a pawl 20, turning of the knob 16 causing a positive displacement to be sensed by the user, or a "click" heard from the pawl when a metered dose of dentifrice has been delivered, the pawl further acting together with the ratchet wheel to prevent the knob 16 from being turned the other way.

In use, the sector-like flaps of the diaphragm open outwardly under pressure of the dentifrice to permit delivery thereof; preferably the diaphragm is formed from a resilient flexible material whereby the flaps close together in the absence of dentifrice pressure, to seal the duct 14 from ambient air. The frusto-conical nozzle permits any dried dentifrice which forms therein to be readily ejected under dentifrice pressure at the next use.

In the embodiment of Figure 3, the brush 21 comprises a head 22 and a body 23 containing gas propellant and a dentifrice. The dentifrice is delivered to the head 22 through the conduit 24. Delivery is brought about either by pressing an operating button or by the application of pressure on the head 22. A valve at 25 releases a predetermined amount of dentifrice into the conduit 24 for delivery of a corresponding amount at the head 22.

In use, dentifrice is delivered to the head 11, 22 by mechanical or gas propulsion and the user cleans his teeth. Once all the dentifrice has been used, the brush may be thrown away.

With reference to Figure 4, the toothbrush head portion has a body 41 to which tufts of bristles 42 are attached in known manner. The body has an internal blind-ended conduit 43 which opens among the tufts at an aperture 44. At the rear end, the conduit opens out to allow for a gas-charged foam dentifrice reservoir to be attached, via annular groove 45, to constitute the handle portion of the brush. An opening is provided at the shoulder 46 of the body.

A lance assembly consisting of a hollow lance probe 47

carried in a mounting block 48 is inserted in the body 41 such that the lance probe lies within the conduit 43 and the lower corner of the block 48 extends through the opening in the shoulder 46. The lance probe is longitudinally slidable in the conduit such that in the forwards position the front or distal end 49 of the lance probe is sealed against the blind end wall of the conduit 43 and in the rearwards position is behind the aperture 44. The lance probe is urged to the forwards position by spring 50 but can be manually retracted against the spring pressure by pulling back on the exposed corner of the block 48, in the manner of squeezing a trigger. The rear or proximal end of the lance probe 47 is formed as a channel 51 in the block 48 and sealingly receives the outlet nozzle of the reservoir (not shown), which incorporates metering means as known in principle, for example, in inhalers for dispensing metered doses of gaseous decongestant compositions.

In use, the user merely squeezes the "trigger" of mounting block 48 to retract the lance probe within the conduit 43 to dispense a metered dose of dentifrice foam through the aperture 44 to the bristles. Release of the "trigger" causes the lance probe to re-seal against the blind end wall of conduit 43 pending the next use.

The blind end wall of the conduit may be provided with a resilient insert which may have a protruding conical face to act as an effective seal member. The lance probe is preferably formed from a plastics material the resilience or pliability of which will in any event enhance the sealing ability. The distal end of the lance probe may be slightly flared to act as a scraper of the internal wall of the conduit at the blind end region and to prevent dentifrice from entering the conduit behind the

aperture 44. The aperture 44 is, as shown, outwardly tapered towards the bristles.

CLAIMS

1. A brush comprising a head portion with bristles extending therefrom, in which the brush includes a reservoir for containing a working liquid composition, the reservoir being in communication with one or more exit ducts in the head portion of the brush and the brush further including propellant means for the working composition and metering means operatively connected with the propellant means to dispense predetermined metered doses of the composition through the exit duct or ducts.
2. A brush according to Claim 1, in which the working liquid composition is a dentifrice or hair styling mousse.
3. A brush according to Claim 1 or Claim 2, in which the brush includes a handle portion and the reservoir is contained in the handle portion.
4. A brush according to any one of Claims 1 to 3, in which the propellant means are mechanical.
5. A brush according to Claim 4, in which the mechanical means comprise a screw-threaded plunger.
6. A brush according to any one of Claims 1 to 3, in which the propellant means comprise a compressed gas.
7. A brush according to of Claims 1 to 5, in which the metering means comprises means to restrict the movement of the propellant means.
8. A brush according to Claim 7, in which the movement restriction means comprise a pawl and ratchet

arrangement.

9. A brush according to Claim 6, in which the metering means comprise a valve which allows a determined volume of propellant gas to be dispensed.
10. A brush according to any preceding claim, in which the exit ducts in the head portion are provided in the bristle-supporting base portion thereof.
11. A brush according to any preceding claim, in which the or each exit duct includes means to prevent access of air to the working liquid composition contained in the reservoir and in any conduit between the reservoir and the duct to prevent the working liquid composition from drying and clogging the duct when the brush is unused.
12. A brush according to Claim 11, in which the means to prevent access of air to the working liquid composition comprise a non-return valve.
13. A brush according to Claim 6, in which the reservoir is connected to the exit duct by a lance-like hollow tube which is slidable in a blind-ended conduit within the head of the brush between respective open and sealed positions, the tube being urged forwards by pressure to seal against the blind end of the conduit.
14. A brush according to Claim 13, in which the blind end of the conduit is formed with a valve or sealing face.
15. A brush according to Claim 13 or Claim 14, in which the open end of the hollow tube is flared to clean the inner surface of the conduit in the region of the exit

duct and to prevent dentifrice from entering the conduit between the lance and conduit and upstream of the exit duct.

16. A brush according to any preceding claim, in which the exit duct is tapered or frusto-conical.

17. A brush according to any preceding claim, in which the brush is a toothbrush and the working liquid composition comprises a dentifrice.

18. A brush according to Claim 17, in which the dentifrice is dispensed to the bristles in the form of a foam.

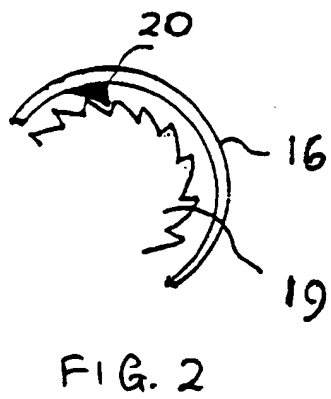
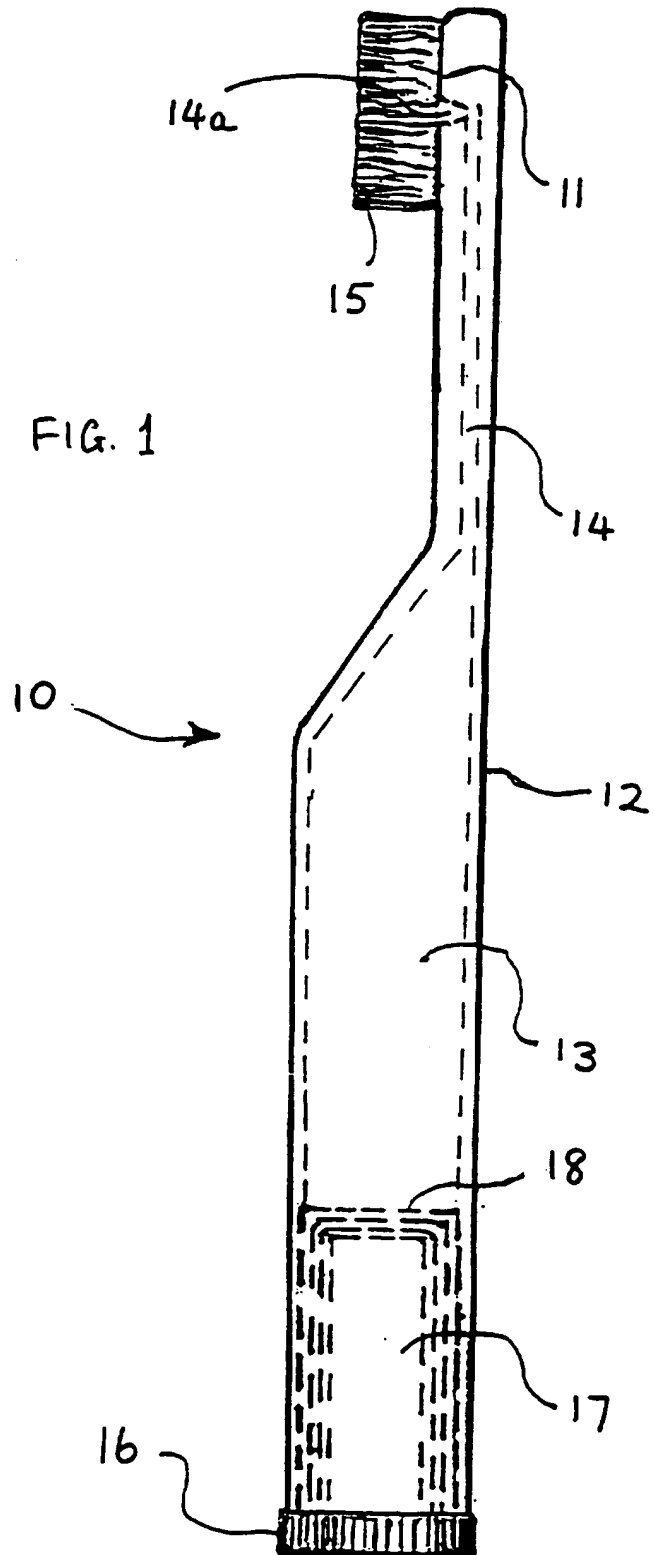

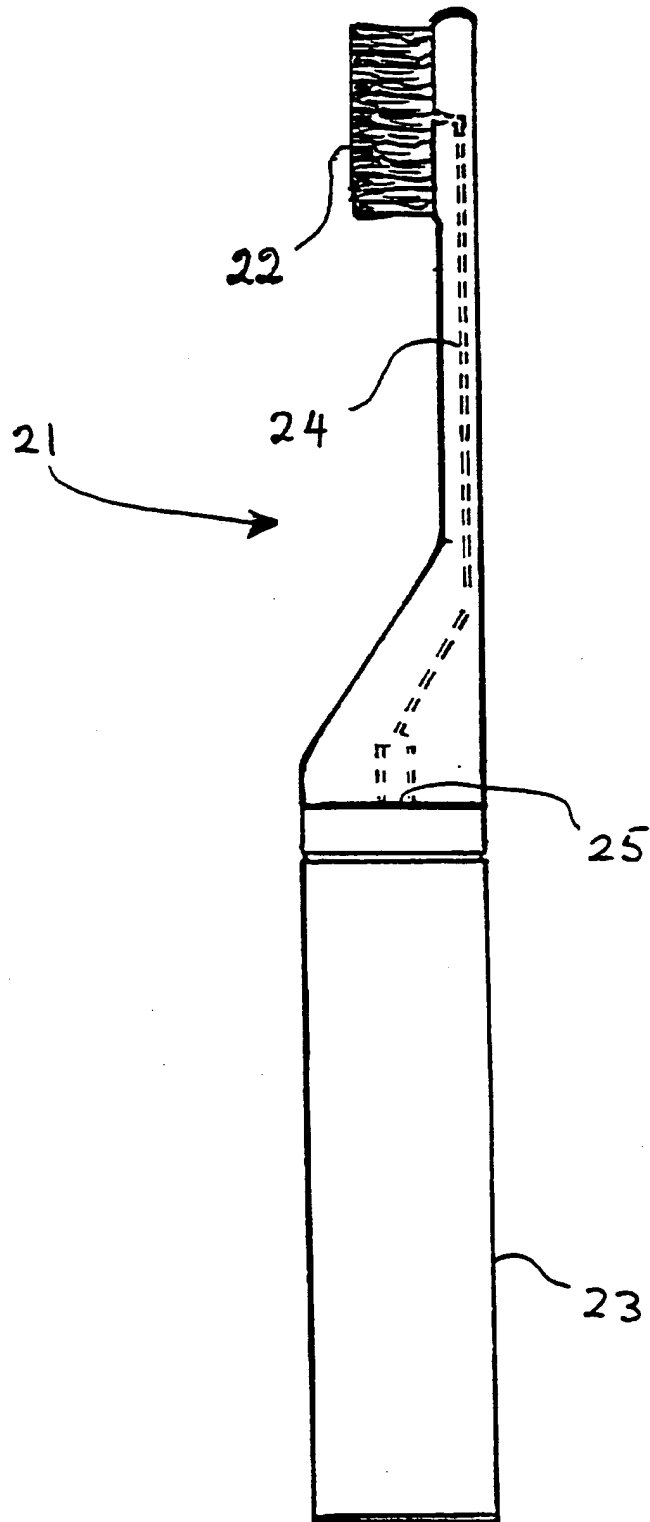

FIG 3

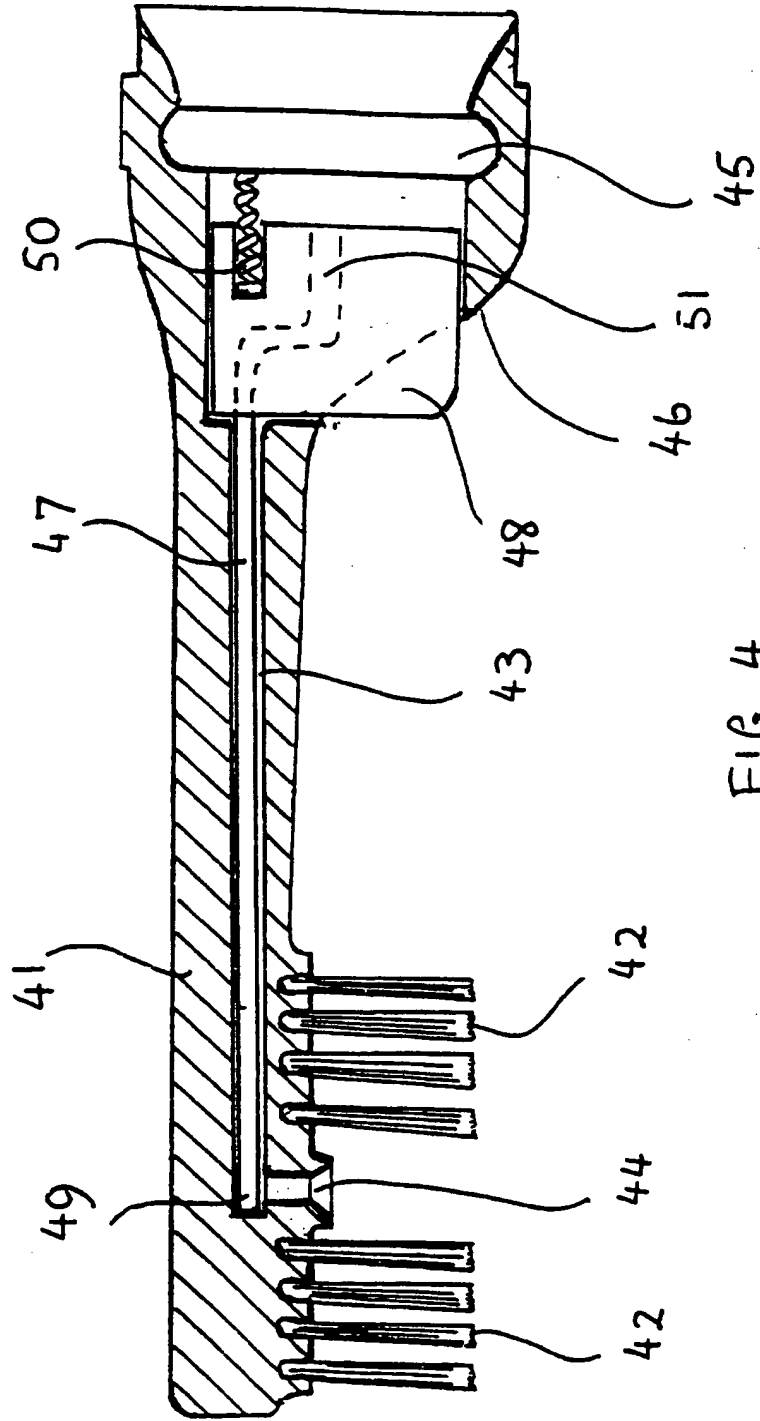

FIG. 4

INTERNATIONAL SEARCH REPORT

Intern. Application No
PCT/GB 96/02509

A. CLASSIFICATION OF SUBJECT MATTER IPC 6 A46B11/00		
According to International Patent Classification (IPC) or to both national classification and IPC		
B. FIELDS SEARCHED		
Minimum documentation searched (classification system followed by classification symbols) IPC 6 A46B		
Documentation searched other than minimum documentation to the extent that such documents are included in the fields searched		
Electronic data base consulted during the international search (name of data base and, where practical, search terms used)		
C. DOCUMENTS CONSIDERED TO BE RELEVANT		
Category *	Citation of document, with indication, where appropriate, of the relevant passages	Relevant to claim No.
X	US 4 013 370 A (GINGRAS ANTOINE) 22 March 1977	1-5,7,8, 10-12,17
Y	see column 1, line 50 - column 4, line 23; figures	6,9,16
Y	--- FR 2 633 500 A (REVERGER MARC) 5 January 1990 see page 2, line 5 - page 3, line 11; figures	6,9
Y	--- WO 83 03742 A (BLACKWELL VICTOR CAMPBELL) 10 November 1983 see figure 18	16
A	--- US 3 383 157 A (GOLDHIRSH BERNARD A) 14 May 1968 see column 2, line 24 - column 4, line 4; figures	1,13
--- -/--		
<input checked="" type="checkbox"/> Further documents are listed in the continuation of box C.		
<input checked="" type="checkbox"/> Patent family members are listed in annex.		
* Special categories of cited documents :		
"A" document defining the general state of the art which is not considered to be of particular relevance "E" earlier document but published on or after the international filing date "L" document which may throw doubts on priority claim(s) or which is cited to establish the publication date of another citation or other special reason (as specified) "O" document referring to an oral disclosure, use, exhibition or other means "P" document published prior to the international filing date but later than the priority date claimed		
"T" later document published after the international filing date or priority date and not in conflict with the application but cited to understand the principle or theory underlying the invention "X" document of particular relevance; the claimed invention cannot be considered novel or cannot be considered to involve an inventive step when the document is taken alone "Y" document of particular relevance; the claimed invention cannot be considered to involve an inventive step when the document is combined with one or more other such documents, such combination being obvious to a person skilled in the art. "&" document member of the same patent family		
Date of the actual completion of the international search	Date of mailing of the international search report	
21 January 1997	07.02.97	
Name and mailing address of the ISA European Patent Office, P.B. 5818 Patentlaan 2 NL - 2280 HV Rijswijk Tel. (+31-70) 340-2040, Tx. 31 651 epo nl, Fax: (+31-70) 340-3016	Authorized officer Ernst, R	

INTERNATIONAL SEARCH REPORT

International Application No
PCT/GB 96/02509

C.(Continuation) DOCUMENTS CONSIDERED TO BE RELEVANT		
Category *	Citation of document, with indication, where appropriate, of the relevant passages	Relevant to claim No.
A	WO 93 03648 A (ENGLISH PHILIP ;SZPAK ANTHONY (US)) 4 March 1993 see page 6, paragraph 5 - page 12, paragraph 2; figures ---	1
A	GB 2 269 090 A (FIRTH) 2 February 1994 see page 3, line 6 - page 8, line 24; figures -----	1

1

INTERNATIONAL SEARCH REPORT

Information on patent family members

International Application No

PCT/GB 96/02509

Patent document cited in search report	Publication date	Patent family member(s)	Publication date
US-A-4013370	22-03-77	NONE	
FR-A-2633500	05-01-90	NONE	
WO-A-8303742	10-11-83	EP-A- 0107647	09-05-84
US-A-3383157	14-05-68	NONE	
WO-A-9303648	04-03-93	CA-A,C 2116119 US-A- 5066155 EP-A- 0599834	04-03-93 19-11-91 08-06-94
GB-A-2269090	02-02-94	NONE	